

平带尺使用说明书 Ribbon Tape Manual

一、平带尺是一种通过检验平底轮辋标定直径或轮辋中某一特定部位直径的周长，来定性评定其标定直径是否符合 GB/T 3487 《汽车轮辋规格系列》标准的专用量具。

1. Ribbon tape gauge is the special measuring tool used to evaluate whether the calibrated diameter is in accordance with the GB/T 3487 (ISO 4209-2: 2001 and ISO 4000-2:2007) by checking the calibrated diameter of flat base rim or the circumference of a certain point of rim.

二、平带尺的构成

平带尺是由测量钢带、测量手柄及标准圈等组成（图 1）。

2. The structure of ribbon tape

Ribbon tape consists of measuring steel strip, measuring handle and standard ring (See Fig.1)



图 Fig. 1



图 Fig. 2

三、使用方法 3. Usage method

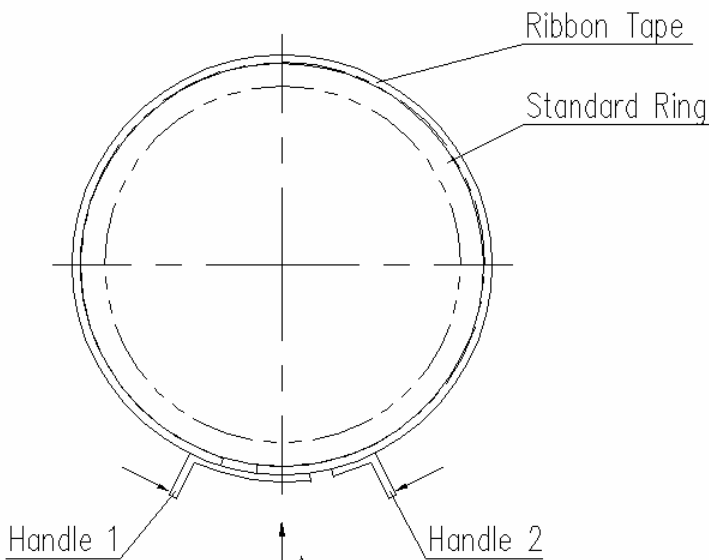
1. 平带尺在使用前应先进行标定。将平带尺置于标准圈上，使测量钢带均接触标准圈的两个垂直面，在手柄上施加 5kg 左右的力，此时手柄 2 端部应对准手柄 1 上的右刻线。

1. The ribbon tape should be calibrated before using. Put the ribbon tape onto the standard ring, which makes the measuring steel strip touching the two vertical sides of standard ring, and apply 5kg force on the handle, at this moment, the two ends of handle should face the right scale mark on handle 1.

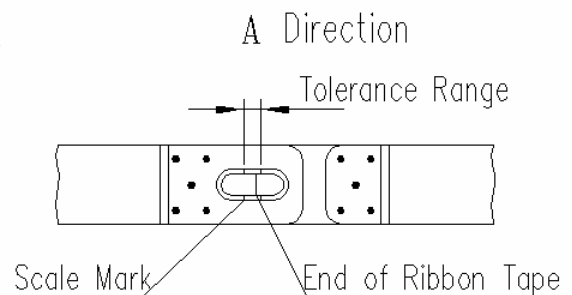
2. 测量工作开始前，应将被测轮辋的测量部位清洁干净。将标定好的平带尺置于轮辋被测处，使测量钢带均匀接触轮辋表面，在手柄上施加 5kg 左右的力，观察左右手柄的刻线位置，如手柄 2 的端部在手柄 1 的双刻线范围内（图 2），则表示轮辋标定直径合格；如偏离该范围，则表示不合格。

2. Before starting measuring, user should clean the measured point of tested rim. And put the calibrated ribbon tape at the measured point of rim, which makes the measuring steel strip touching rim surface evenly, and apply 5kg force on the handle, and then check the scale mark position of left and right handles. If the end of handle 2 locates within the double scale marks of handle 1 (See Fig.2), then it shows that rim calibrated diameter is qualified; if the end of handle 2 locates out of the double scale marks of handle 1, which means that the rim calibrated diameter is unqualified.

四、注意事项 4. Notices

1. 每一规格尺寸的平带尺只能用于检测同种规格的轮辋。

1. The ribbon tape gauge of each size can measure the same size rim only.

2. 测量工作应由两人进行操作，一人辅助持尺，保证测量钢带全部接触被测部位，另一人进行测量判定。

2. The rim measuring should be done by two persons, one person holds the ribbon tape gauge to ensure the steel strip touching the measured points totally, and the other person performs the measuring steps.

3. 平带尺在使用时应轻拿轻放；不使用时，应置于标准圈上进行保存。为避免锈蚀，平带尺和标准圈均应涂有防锈油脂。

3. The ribbon tape should be taken gently during using. After measuring is finished, the ribbon tape should be kept and stored on the standard ring. In order to avoid rusting, ribbon tape and standard ring should be lubricated with anti-rust grease.

——以上——

天津久荣车轮技术有限公司
Tianjin Jiurong Wheel Tech Co., Ltd

ADD: 天津市南开区延安路 18 号中欣工业园内

ADD: Zhongxin Industrial Zone, Yan An Rd, Nankai Dist, Tianjin, (300112) P.R.China

TEL: +86-22-27519210 FAX: +86-22-27519630

E-mail: guzheng@126.com, sales@jiurongwheel.com